



CONTENTS

1.0 Introduction	3
2.0 Applying for a Licence	3
3.0 Licence Conditions	5
4.0 Size, Layout and Means of Enclosure	5
5.0 How an Application will be Determined	6
6.0 Furniture and Visual Impact	8
7.0 Umbrellas & Awnings	8
8.0 Environmental Implications	9
9.0 Litter/Cleansing	9
10.0 Noise	10
11.0 Other Requirements	10
12.0 Further Information and Contact Details	11
13.0 Fees Payable	12

1.0 Introduction

Street cafes add to the colour and atmosphere of towns in the County Borough and offer a popular service for residents and visitors alike. The pedestrianised areas in particular lend themselves to eating and drinking outside in warmer weather. Where they are provided the Council is keen that street cafes be good quality and properly designed, contributing to a relaxed and sociable mood.

A street cafe not on privately owned land must be licensed by the County Borough Council, as the Highway Authority, to ensure that it is properly set up and operated so that it benefits the business, enhances the town centre and does not cause a problem for other users of the street.

Licences will be issued for a maximum of a year. Factors taken into account when considering an application will be:

- the amount of space the cafe will remove from the public highway
- how it will look when it is up and running
- the effect it may have on local residents, workers, shoppers and visitors.

Applications that simply seek to place tables and chairs outside without any effort to meet the required standards will be refused.

Applicants for street café licences relating to premises in Neath town centre should note that, depending on the specific location, any licence issued may not be valid for the period of Neath Fair in September each year.

2.0 Applying for a Licence

To apply for a new licence

You should write or telephone Environment (see section 12 for contact details) to request an application form.

With your formal application you will need to provide the following:

- A completed application form.
- The relevant payment, for the proposed number of tables and chairs.

- A sketch plan of the proposed street café area, showing its extent, the relationship to any existing street furniture (seats, planters, lighting columns, etc), and the proposed arrangement of tables, chairs and umbrellas/awnings.
- Details of the proposed furniture and of the barriers which will surround the café area.
- Details of any lighting and/or heating arrangements for the street café, if these are proposed to be provided.
- Evidence of Public Liability Insurance to the value of £2 million.
- Proof of any necessary related approvals, eg planning consents.

Following the receipt of an application, the following Council departments and other organisations will be notified to ensure that your proposal is acceptable to them. They include:

Planning	Town Centre Management
Legal Services	Environmental Health
Local Councillors	Waste Management
Police	Fire and Rescue Service
Ambulance Service	

To renew an existing licence

Without change, you will need to provide:

- a completed application form,
- the relevant fee per table/chair
- evidence of ongoing Public Liability Insurance.

If you propose to reduce the area covered and/or the number of tables and chairs, a sketch plan of the revised layout will also be required.

A renewal involving an increase in either the area covered or the number of tables/chairs will be treated as a new application (see above).

3.0 Licence Conditions

Each application will be considered on its merits and its suitability to the local environment. When a licence is granted, the licence holder must adhere to the conditions set out in this guide and on the licence itself, otherwise the Council will have no choice but to remove any furniture causing an obstruction and may have to consider revoking the licence or refusing its renewal.

4.0 Size, Layout and Means of Enclosure

The Council appreciates that you will want to organise your street cafe in a way that is attractive and will encourage customers to enjoy food and drink from your premises. However, the following factors have to be taken into consideration when planning the cafe layout:

- Available space
- Type of premises
- Street width
- Street character
- Number of passers-by
- Existing street furniture, eg benches, planters etc
- Other street cafes nearby
- Residential properties

The needs of people using the town centre are of paramount importance when considering cafe layout and size - pedestrian flows, access and freedom of movement for disabled people, access for emergency vehicles etc. The layout, type and colours of the tables and chairs used, along with access points and the way the cafe is enclosed, also need approval and this information must be provided as part of the application. It is essential that the cafe does not cause an obstruction or inconvenience to members of the public, particularly people who are disabled, so adequate space must be left between tables and chairs for wheelchair access. When the cafe is in use during the hours specified in the licence, it must be enclosed by a removable barrier, with access points, to separate it from the main thoroughfare. Outside licensed hours, all barriers, furniture, etc must be removed, to allow free access to the pavement or pedestrianised area.

5.0 How an Application will be Determined

The Council will have to be sure that the application meets the following requirements:

- Street cafes will only be allowed on pavements where a minimum width of 2 metres can be left clear and unobstructed for pedestrians. This is to ensure that pedestrians, particularly the visually impaired, are not obstructed. In a very busy street it may be necessary to leave more than 2 metres of footway space for pedestrians.

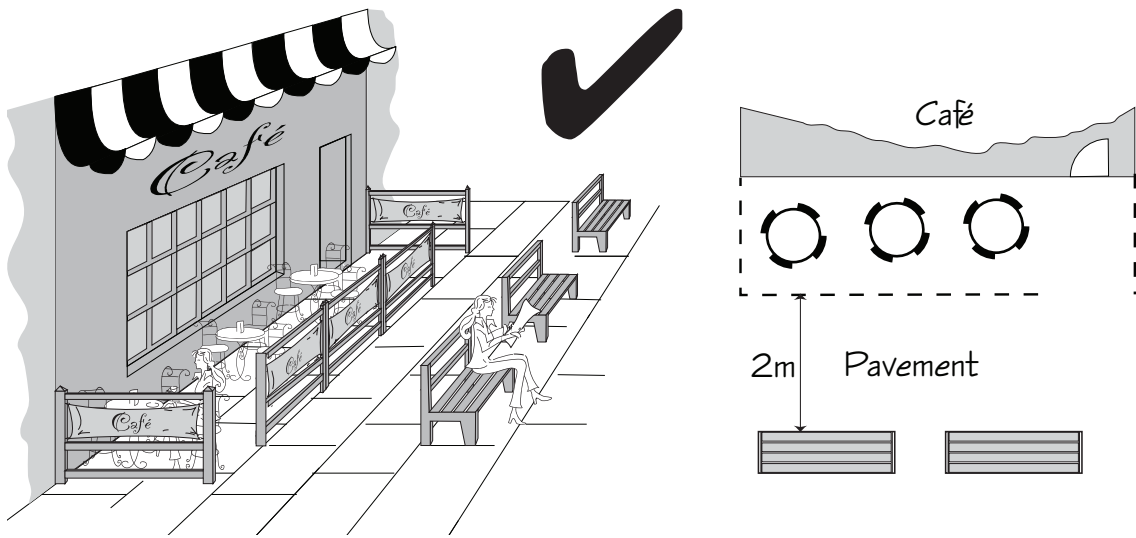

- The way tables and chairs are set out should not prevent or discourage people from using the footway - the route available to them must be straightforward, obvious and unobstructed.

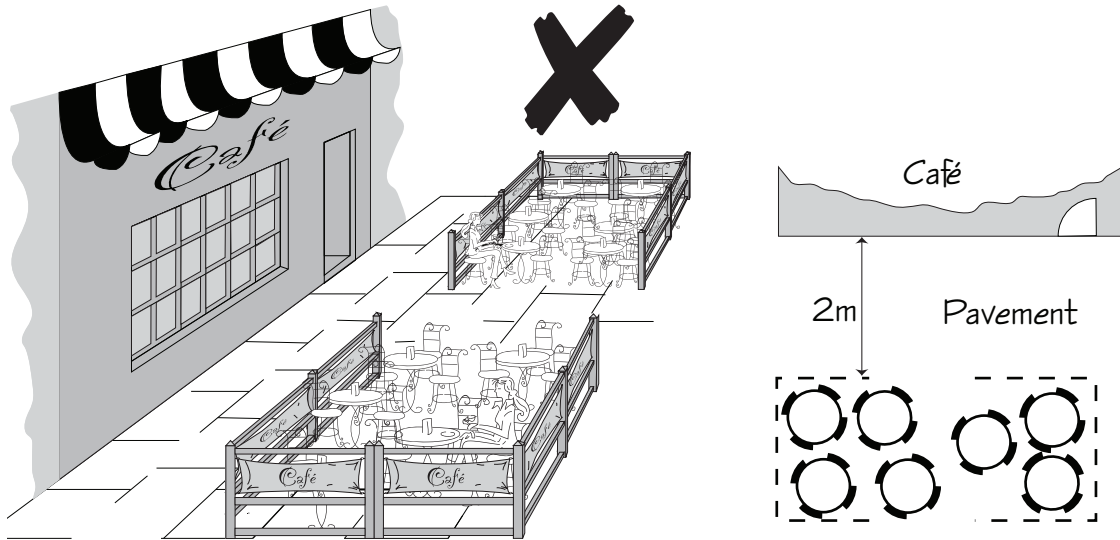

- The cafe should be located immediately outside the front of the applicant's premises so that staff and customers do not have to cross the normal flow of pedestrians.
- In pedestrianised areas a clear route at least 4.0 metres wide in front of any street café area is required to ensure free and unobstructed access for the emergency services and other authorised vehicles.
- Toilet facilities must be provided for customers. If the facilities are not suitable for wheelchair users, customers must be made aware of this.
- The cafe must be surrounded by a removeable continuous physical barrier on all sides open to the highway, with defined access points. The barrier should be of a style, material and colour sympathetic to the local environment. It must be not less than 800mm high and either continuous to the ground or incorporate a lower rail or tap board within 100 - 150mm of ground level to help people who are visually impaired. It should not have sharp edges or protruding parts and should be of lightweight construction so it is not too visually dominant and can be easily dismantled. However, it needs to be strong enough to withstand outdoor public use.

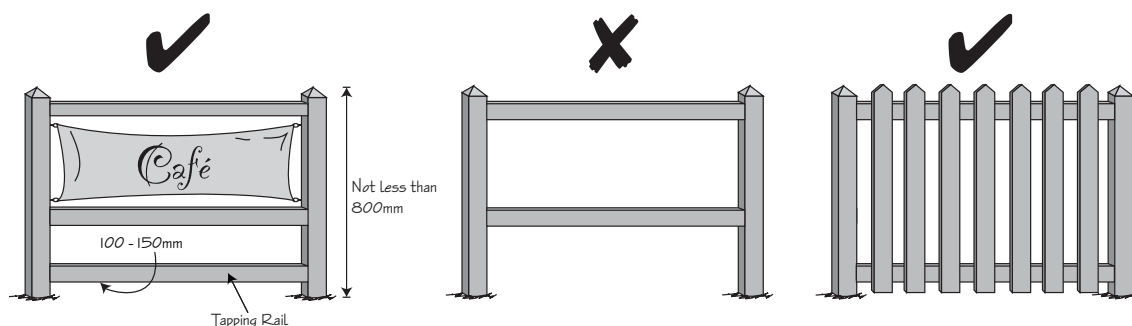

- All furniture, umbrellas, displays and advertising signs must be kept inside the barriers.
- Street furniture provided by the Council, eg benches, lighting, bollards etc, should not be included in a licensed area.

6.0 Furniture and Visual Impact

The Council expects outdoor furniture to be of a high quality design and made of durable materials. Tables and chairs should be stylish and well co-ordinated and in colours that are not garish, bright or overly reflective. White plastic garden-type furniture is not appropriate. Table design should allow use by people in wheelchairs so this needs to be taken into account when considering the clearance under table tops, position of table legs etc. The type of furniture proposed to be used must be submitted as part of the application and if it is considered unsuitable it could be grounds for refusal.



The Council also reserves the right to require certain items of furniture to be removed if they are considered inappropriate, even though they were approved in the original licence application. This could happen if the furniture becomes:

- unsightly or unsafe through poor maintenance
- inappropriate because of new development in the vicinity

Unless agreed, all furniture must be removed from the highway outside the times of the licence.

7.0 Umbrellas & Awnings

If umbrellas are to be used they must be specified as part of your licence application, including where they are to be placed, their material and colour.

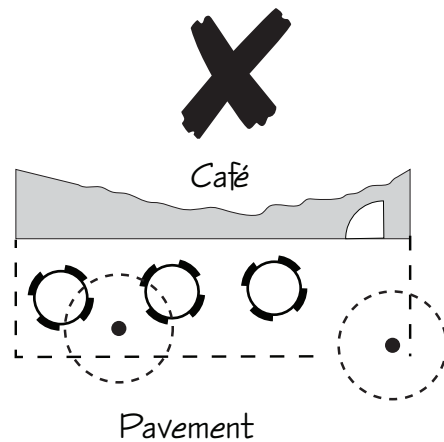
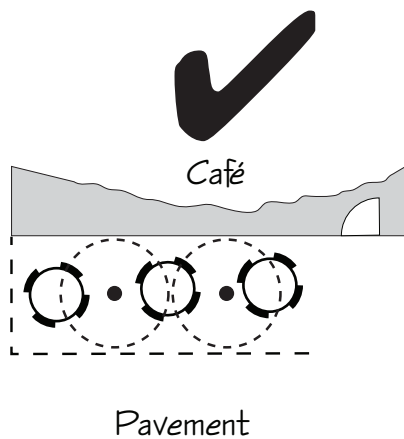

They must be positioned so that, when open, they cannot spread outside the licensed area and create a potential danger to passers by or vehicles.

If you are considering fitting an awning to the frontage of your premises, which can be extended over the proposed street café area, then planning consent may be required. For advice please contact the Council's Planning Section.

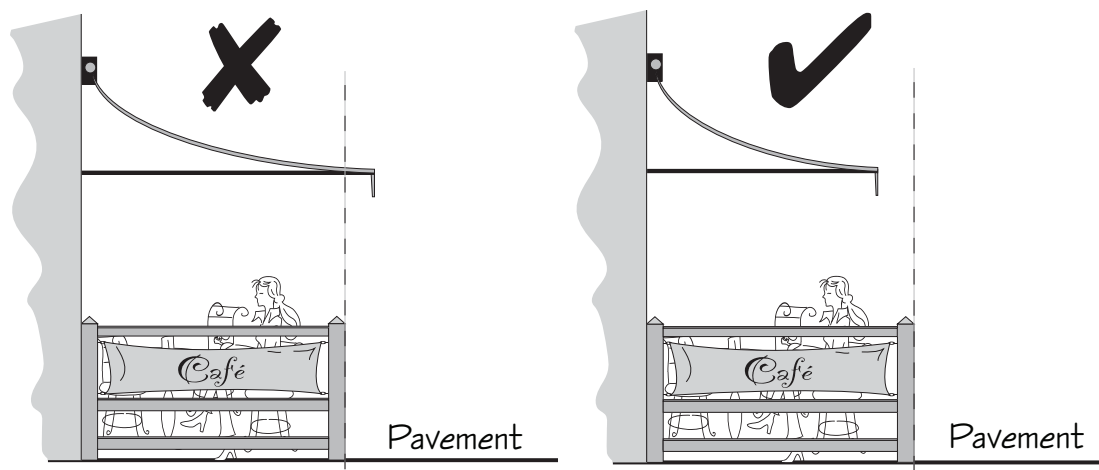

8.0 Environmental Implications

It is vitally important that the environment - for customers, members of the public, local residents and staff - is a prime consideration in any application. For further information or help regarding Environmental Health matters please contact the Council's Environmental Health Section.

9.0 Litter/Cleansing

Tables are to be cleared as soon as they become vacant and the area as a whole is to be kept clean, tidy and litter-free. The licensed area and, in a pedestrianised area, at least 5 metres surrounding it or, on a pavement, at least 5 metres to each side of it and up to the edge of the pavement, must be swept and kept free of litter and debris at all times.

10.0 Noise

The Council must be satisfied that your street cafe proposal will not result in noise nuisance to nearby residential accommodation or other noise sensitive premises, eg solicitors, counselling or therapy services. In certain circumstances this may mean that a cafe can only operate within restricted hours - or indeed, may not be allowed at all. No outside music is allowed - either played within the licensed area or conveyed to it from inside your premises.

11.0 Other Requirements

- A clear, visible price list which can be easily read by potential customers, as required by the Price Marking (Food and Drink Premises) Order 1979.
- Customers must be seated. The cafe is approved in terms of the number of seats and when these are full and customers stand in the licensed area it increases patronage beyond that approved under the terms of the licence. Failure to comply with this, and on recommendation of the police, could result in the licence being revoked.
- If you propose to provide lighting and/or heating for the street cafe then details must be submitted as part of the application. Permanent lighting is not acceptable in the licensed area or the highway. Lighting may need separate planning consent and is not covered in the granting of a street cafe licence. For advice please contact the Council's Planning Section. No exposed cabling will be permitted across the highway.
- The licensee(s) must have Public Liability Insurance to a value of £2 million. Evidence of this must be submitted with the application - a copy of the insurance certificate is sufficient. The licensee will indemnify the Council as the Highway Authority against any claims that may arise and is also expected to clear the licensed area for normal highway use outside the times of the licence.
- Proof of related approvals will be required as part of the application.
- Statutory undertakers (gas, electricity and water) have the right to carry out work within the highway so the licensed area must be made available to them at any time, even if this prevents the operation of the street café for a period.

- It is the responsibility of the licensee to ensure that the conditions of the licence are adhered to. The Council, under the Highways Act 1980, has powers to ensure compliance with the terms and conditions of the licence and to recover any expenses incurred.
- No items, including food or drink of any description, may be sold on to the public highway from within the approved area.
- Additional guidelines may be added to licences as and when necessary.
- Licences are generally granted for a year, although they may be for a shorter period if there are particular concerns. There will be no reduction in fees for shorter period licences.
- Details of the fees payable are shown in section 13 below.
- If any alterations to the highway or to street furniture provided by the Council are required to accommodate the licence they will be paid for by the applicant, eg re-location of public seating.

12.0 Further Information and Contact Details

If you need any further information or assistance, please contact Environment on (01639) 686836.

Completed application forms should be submitted to:

Streetworks Admin.
Neath Port Talbot County Borough Council
The Quays
Brunel Way
Baglan Energy Park
Briton Ferry SA11 2GG

For related licensing, please contact the Licensing Section:

Neath Port Talbot County Borough Council
Neath Civic Centre
Neath SA11 3QZ

For related licensing, environmental health issues, please contact the Environmental Health Department:

Environmental Health:
Neath Port Talbot County Borough Council
Neath Civic Centre
Neath SA11 3QZ

Telephone (01639) 764347

Email: ehs@npt.gov.uk

Web: www.npt.gov.uk/ehs

13. Fees Payable

There is a £10 charge for each table and for each chair per year.

Please enclose a cheque made payable to Neath Port Talbot County Borough Council with your application form. Should your application be unsuccessful your cheque will be returned.

Licenses are issued for a maximum period of a year.